

Design of Combined Cam and Piercing Progressive Die Set for a Sheet Metal Component

R. Rahul¹ and M. Thenarasu²

¹Undergraduate Student, Department of Mechanical Engineering, Amrita School of Engineering, Coimbatore, Tamil Nadu, Amrita Vishwa Vidyapeetham, India.

²Assistant Professor, Department of Mechanical Engineering, Amrita School of Engineering, Coimbatore, Tamil Nadu, Amrita Vishwa Vidyapeetham, India.

(Corresponding author: Thenarasu M.)

(Received 25 April 2020, Revised 18 May 2020, Accepted 20 May 2020)

(Published by Research Trend, Website: www.researchtrend.net)

ABSTRACT: Sheet metal working is an integral part of any major automotive industry. Die designing is one of the cornerstones of sheet metal forming in the industries. Progressive die is designed to perform piercing, cutting and bending operations on a work piece. Researchers from various parts of the world have worked on to improve the design of the die sets to improve the utilization of the machine. In this work, a cam and piercing progressive die set is designed and analyzed. The component is processed in two different machines using separate tools and labour for each machine. Hence the industry is facing problem in terms of extra handling, extra labour, cost, time and utilization. The objective of the paper is to combining three processes in a single machine by designing a progressive die set thereby increasing the utilization of the machine and decreasing the time and costs for manufacturing the component in the industry. In the proposed design, the move time has been eliminated completely and 33.3% decrease in time is observed in proposed design.

Keywords: Progressive die design, Blanking, Bending, Manufacturing cycle time reduction.

I. INTRODUCTION

The manufacturing industry is one of the important sectors of a country. In the manufacturing sector, sheet metal forming is one of the basic but ubiquitous process. Sheet metal manufacturing is preferred because they are economical and faster means to mass produce intricate, durable and accurate components. The progressive die was first developed in the 1950s in order to keep up with the ever growing demand. Improvements have been made to the design continuously over the years in order to reduce the manufacturing time and the number of defective products. The advantages of the proposed system in this study include a considerable reduction in the manufacturing cycle time when compared to the previous studies and reduced miscellaneous operation costs. Quantitative reductions have been compared in manufacturing cycle time for the die design as opposed to the previous studies. A progressive die performs many sheet metal operations at two or more work stations. The work piece is transferred from one stage to another stage with different operations. All stations work simultaneously at different points along with the work piece. A combined machine doing multiple operations is generally more efficient than a series of machines. Progressive dies are preferred in industries for the higher production rate and due to a variety of operations like blanking, bending, curling and piercing that can be done on the work piece by a single machine. Different steps are integrated within a single die, allowing more tooling solutions in quick and cost effective manner. With the advent of modelling and simulation software, the components can be produced more precisely in large numbers. For the production of the components in large numbers, it must be ensured that the each machine

involved in making the component is utilized fully. It is necessary for the manufacturing engineers to keep increasing the bar of utilization to the maximum [1-3]. With the rising need for quality products in huge numbers, optimization of the manufacturing processes is an urgent need in any industry. Press and compound die sets are one of the machines which are in operation for most of the time and are widely used across many industries. The reduction of cost due to one less machine can save a huge amount of money for the industry in power usage, time and labour costs. In addition to that, an optimized die layout can also decrease the material costs for that component. Combining the operations of two machines are currently used for making a single component as shown in the Fig. 1. This leads to increase in time, increase in labour costs and handling costs. The present machine in the industry is being underutilized.

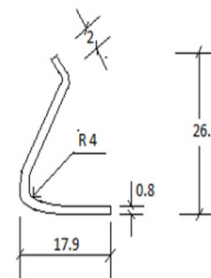

Fig. 1. Component diagram.

The Fig. 1 shows the component that has to undergo piercing, cutting and bending processes in order to be

manufactured from a metal strip.

The existing manufacturing process involved two machines. Piercing and cutting operation is done by one machine with automatic feed. Another machine is used for bending the work piece and requires manual feed. A progressive die is to be designed such that the component is manufactured faster and more efficiently using a press tool.

II. TRENDS AND DEVELOPMENTS

Designing of progressive die have been studied and analyzed for about seventy years now. The die design can not only reduce the cost of material but also serves to decrease latent costs like time and handling costs in a manufacturing process. The compound tools are similar to progressive tools but with some differences as the compound tools performs only two operation at a time, whereas the progressive tools does multiple operations at the same time. The working of compound dies are extensively discussed in different literatures from the classification of dies, design calculations and software tools for designing efficient die layout to minimize wastage. The commonly used design methodology is discussed in many books and literatures listed [4-6] to explain the sheet metal operations and manufacturing considerations. Some case studies of die design for different components are done with finite element analysis to check for failure [9-11, 16]. The previous studies in this area is primarily concentrated on the finite element method and stress analysis of the die design.

A number of factors can affect the die design and the operation itself discussed in the literature. Lahadotiya *et al.*, (2013) studied the recent trend and developments in die design [13]. Cheok and Nee (1998) have also explored the trends in the use of automation and computer aids in the development of tools for metal stampings [15]. Kumar and Singh (2010) proposed an ESPDIE, system for the design of progressive die using CAD and Artificial intelligence technology collectively [8]. A feature based progressive tool design system was developed by Ismail *et al.*, (1996) to propose the die layout required to produce a component [14]. The study in development of progressive die for U-bending is taken as reference for many computer aided technology [12]. Difference factors affecting the design like clearance and the geometric orientation of the work piece are discussed [7]. The recent studies in this area which implements the use of Artificial intelligence for the fully independent working of the machine have also been discussed by Kumar and Singh [8].

III. METHODOLOGY AND CALCULATIONS

A. Strip Layout

The purpose of strip layout is used to ensure that the strip is guided to the die block surface and the blank. The feed is taken to be length of the strip which is 41.3 mm. The feed is taken to be length of the strip which is 41.3 mm.

The Fig. 2 illustrates the strip layout design made using CAD software. It can be observed that there is no wastage of the metal strip apart from the blanks due to piercing operations.

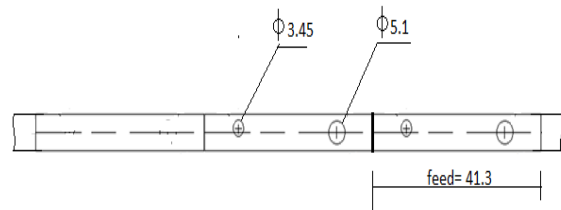

Fig. 2. Strip layout.

B. Cutting Force

Cutting force is the force applied on the stock materials to cut out the scrap from the strip. Since it is a progressive die, both the piercing operations (radii 3.45 mm and 5.1 mm) have to be considered for the cutting force calculations.

Cutting Force (Perimeter \times Thickness \times Shear strength) = 1.001 ton

Actual tonnage required is 33% more press capacity = 1.33 ton

C. Die Block Thickness (T)

The die block thickness is the female of half the mated tool. The die block thickness can be taken from the design data book for its respective perimeter value.

P (perimeter of the component) = $(41.3 \times 2) + (8 \times 2) = 98.6$ mm

Comparing the perimeter value, the corresponding value for die block thickness is taken to be 25mm.

D. Die Clearance

A proper clearance between the die and punch is essential for piercing a hole efficiently. A larger die clearance can result in rollover deformation. Allowable clearance is 2.5-5% of sheet thickness. Piercing calculations are done for the holes with diameters 3.42 mm and 5.1 mm respectively.

Piercing of \varnothing 3.42 mm

Punch diameter = \varnothing 3.42 mm

Minimum diameter clearance = $2.5/100 \times 0.8 = 0.02$ mm

Maximum die clearance = $5/100 \times 0.8 = 0.04$ mm

Minimum die size = $3.42 + (0.02 \times 2) = 3.46$ mm

Maximum die size = $3.42 + (0.04 \times 2) = 3.5$ mm

Piercing of \varnothing 5.1 mm hole

Punch diameter = \varnothing 5.1 mm

Minimum clearance = $2.5/100 \times 0.8 = 0.02$ mm

Max clearance = $5/100 \times 0.8 = 0.04$ mm

Minimum die size = $5.1 + (0.02 \times 2) = 5.14$ mm

Die size (maximum) = 5.18mm

E. Bending Force

Bending Force is the force if forming a free bend. In the bending operation, bottom bending is used in order to stabilize the shape.

$$\text{Bending force} = \frac{C \times b \times t^2 \times \sigma_{\max}}{W} \quad (1)$$

Where, $W = 2(R_1 + C_b + R_2) = 17.88$ mm, C is constant of proportionality, C_b is the bending clearance, R_1 and R_2 are the radii of punch respectively, b is the bending line length, t is plate thickness, σ_{\max} is the tensile strength of the material. Substituting the values of the variables from the Eqn. (1), the required bending force is calculated in the equation

$$\text{Bending Force} = \frac{1.2 \times 8 \times 0.64 \times 450}{2(4+0.8+(0.05 \times 0.8)+4.1)} = 155 \text{ N}$$

F. Spring Back

If the stress is less than the yield stress there will be no permanent distortion (deflection). The bent piece will spring back to original unbent position.

For CRCA material yield stress is 29 kg/mm

For this value, $25 = (E/R) \times Y$ (2)

Where, E = Young's modulus = 2.1×10^6

R= Maximum bend radius, Y= Distance from neutral axis = $t/2 = 0.4$ mm

Therefore, R= 289.6 mm

IV. RESULTS AND ANALYSIS

The proposed progressive die design made on CAD software is shown for the different operations done on the work piece. The Figs. 3 to 6 illustrates the proposed design for piercing assembly, cutter assembly, bending punch and bending die respectively.

Proposed Piercing assembly

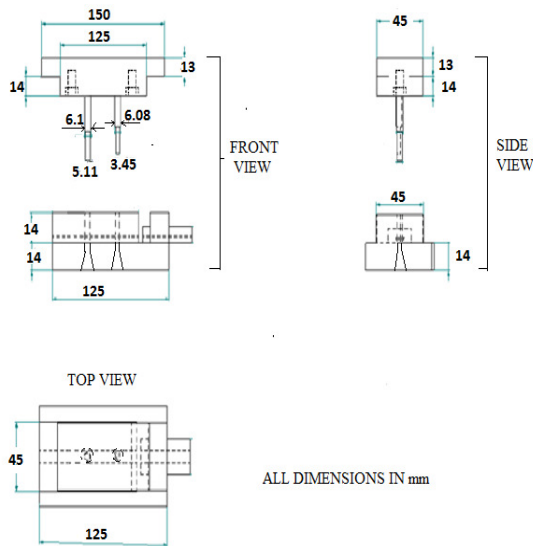

Fig. 3. Proposed piercing assembly.

Proposed Cutter design

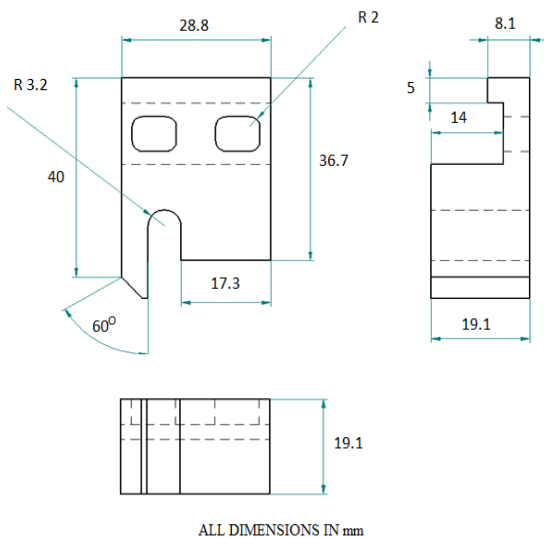

Fig. 4. Proposed cutter design.

Proposed Bending punch

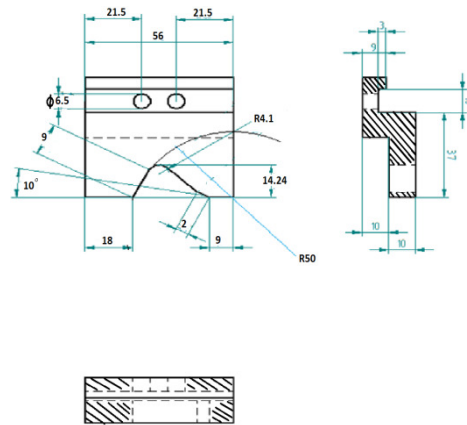

Fig. 5. Bending punch.

Proposed Bending Die

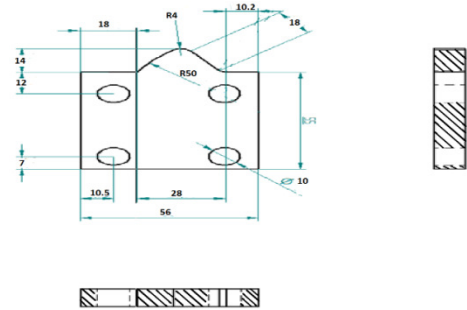

Fig. 6. Bending die.

Time taken for manufacturing the given component includes processing time and move time. Process time is the time taken to machine the work piece. Transfer time is the time required to transfer the work piece from one station to other station. The total cycle time was 30 seconds in the existing setup including the time taken to load the component for the bending operation. In the proposed design, the move time has been eliminated completely and the processing time was brought down to 20 seconds due to progressive die as shown in Fig. 7.

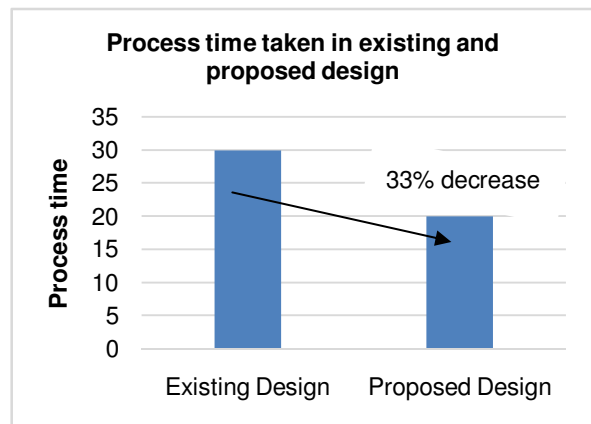

Fig. 7. A 33.3% decrease in time is observed in proposed design.

V. CONCLUSIONS

The piercing and bending operations were performed on two different machines. Piercing operation was done on the hydraulic pressing machine and bending operation was done on two manually operated hand presses. The combining of machines have led to reduction in processing time, labour costs and handling costs.

To eliminate travel between these two machines and to minimize labour and time, it was decided to design and manufacture a combined piercing and bending tool that could be mounted on one of the machines, thus eliminating the other machine. Force calculations have been done to eliminate chipping problems in the die.

The combined cam and piercing progressive die set was designed for the machine. This machine was earlier underutilized and was at 30%, now adding the manufacture of the bracket to the machine will definitely improve the utilization of the machine.

VI. FUTURE SCOPE

Production technology is increasing greatly every day in order to cater to the ever growing demand. This has led to research and development in various avenues like applications of computer vision and tool monitoring in manufacturing which will further lead to reduction in use of workers. Computer vision can be used to check for the defects as soon as the product is out of the machine. Similarly, better sensors have been developed to equip the machine with tool condition monitoring in real time. Machine learning algorithms are used in all the machines for real time analysis of the subsystems.

Conflict of Interest. The authors don't have any conflicts of interest.

REFERENCES

- [1]. Mohanavelu, T., Krishnaswamy, R., & Marimuthu Prakash, K. (2017). Simulation Modeling and Development of Analytic Hierarchy Process (AHP) based Priority Dispatching Rule (PDR) for a Dynamic Press Shop. *International Journal of Industrial and Systems Engineering*, 27(3), 340-364.
- [2]. Neeraj, R. R., Nithin, R. P., Niranjhan, P., Sumesh, A., & Thenarasu, M. (2018). Modelling and simulation of discrete manufacturing industry. *Materials Today: Proceedings*, 5(11), 24971-24983.
- [3]. Jhony, J., & Thenarasu, M. (2019). Productivity Enhancement In A Pressure Vessel Manufacturing Industry Using Lean Principles. *International Journal of Innovative Technology and Exploring Engineering*, 8(8), 3272-3279.
- [4]. Spitler, D., Lantrip, J., Nee, J. G., & Smith, D. A. (Eds.). (2003). *Fundamentals of tool design*. Society of

Manufacturing Engineers.

- [5]. Dallas, D. B. (1962). *Progressive Die Design and Manufacture*. McGraw-Hill Book Company.
- [6]. Smith, D. A. (1990). *Die design handbook*. Society of Manufacturing Engineers.
- [7]. Subramonian, S., Altan, T., Ciocirlan, B., & Campbell, C. (2013). Optimum selection of variable punch-die clearance to improve tool life in blanking non-symmetric shapes. *International Journal of Machine Tools and Manufacture*, 75, 63-71.
- [8]. Kumar, S., & Singh, R. (2010). An expert system for design of progressive die for use in sheet metal industries. *Journal of Scientific and Industrial Research*, 69(7), 510-514.
- [9]. Mastanamma, C., Rao, K. P., & Rao, M. V. (2012). Design and Analysis of Progressive Tool. *International Journal of Engineering Research & Technology*, 1(6), 1-10.
- [10]. Kumar, K. K., Srinath, A., Naveen, M., & D, R. (2012). Design of Progressive Dies, 2(3), 2971-2978.
- [11]. Rehaman, I., Reddy, P. S., Manoj, M., & Murthy, N. G. (2019). Design and Analysis of Progressive Die for Chain Link Plate. *International Journal of Recent Technology and Engineering*, 8(4), 820-826.
- [12]. Sim, S. B., Lee, S. T., & Jang, C. H. (2004). A study on the development of center carrier type progressive die for U-bending part process. *Journal of Materials Processing Technology*, 153-154(1-3), 1005-1010.
- [13]. Lahadotiya, K. K., Kakirde, A. D., & Pandey, A. K. (2013). Mini Review on Designing of Press Tools for Sheet Metal Parts. *Journal of Environmental Science, Computer Science and Engineering & Technology*, 2(3), 650-660.
- [14]. Ismail, H. S., Chen, S. T., & Hon, K. K. B. (1996). Feature-based design of progressive press tools. *International Journal of Machine Tools and Manufacture*, 36(3), 367-378.
- [15]. Cheok, B. T., & Nee, A. Y. C. (1998). Trends and developments in the automation of design and manufacture of tools for metal stampings. *Journal of Materials Processing Technology*, 75(1-3), 240-252.
- [16]. Pawar, S. S. (2014). Computer Assisted Compound Die Design: a Case Study. *International Journal of Research in Engineering and Technology*, 03(05), 465-469.
- [17]. Annigeri, U. K., & Deepthi, Y. P. (2017). Design and development of progressive tool for manufacturing washer. In *AIP Conference Proceedings* (Vol. 1859, No. 1, p. 020107). AIP Publishing LLC.
- [18]. Annigeri, U. K., & Deepthi, Y. P. (2014). Design, Development and Analysis of Forming Tool for Side Panel of an Automobile, 30-33.

How to cite this article: Rahul, R. and Thenarasu, M. (2020). Design of Combined Cam and Piercing Progressive Die Set for a Sheet Metal Component. *International Journal on Emerging Technologies*, 11(3): 570-573.